



## SHURflo LOW VOLUME (SLV) INDUSTRIAL SERIES PUMPS

SHURflo offers various pump models for different applications. The information outlined by this manual is general, and not specific to all SHURflo Low Volume (SLV) series pumps.

### FEATURES:

SHURflo Low Volume (SLV) Series 1.0 gpm are rugged, light weight, compact and provide the ability to self-prime and run dry. Standard features include a pressure demand switch, built in 3/8" hose barb ports, flexible mounting feet, splash proof motor, and thermal protector.

### OPTIONS INCLUDE:

Inline 5 amp fuse with holder.

Manual on/off switch and two-pin power connector.

### INSTALLATION:

SHURflo Low Volume (SLV) Series pumps are self priming and can be located up to 2.5 feet above the water level. Horizontal and vertical prime vary depending on the fluid viscosity and pump configuration. The pump can be at the same level or below the tank.

- The pump should be located in an area that is dry and protect the pump from excessive heat by providing proper ventilation.
- Use 50-mesh strainer minimum at the inlet side of the pump. Use flexible hose on inlet.
- The pump can be mounted in any position. However, if mounting the pump vertically the pump head should be in the down position so that in the event of a leak, fluid will not enter the motor.
- For Spot Spraying applications, use #8 spray tip or larger.

NOTE: Restrictions on the inlet may cause vacuum levels to reach the fluid vapor pressure, causing cavitations, degassing, vapor lock and a loss in performance.

### ELECTRICAL

- 12 Volt pump must be provided with a 5-amp fuse.
- Recommended wire size is 16 gauge (1.3 mm) or larger wire as determined by voltage drop. Negative (-) must be connected to a known ground. Ground wire must be the same (gauge/mm) as the positive.

## TROUBLESHOOTING

### PUMP WILL NOT START:

- ✓ For correct voltage (+10%) and electrical connections
- ✓ Fuse or breaker
- ✓ Pressure switch operation and correct voltage at switch
- ✓ Rectifier or motor for open or grounded circuit
- ✓ For locked drive assembly

### PUMP WILL NOT SHUT-OFF:

- ✓ Output line closed and no leaks
- ✓ For air trapped in outlet line or pump head
- ✓ For correct voltage to pump
- ✓ Debris in pump Inlet/Outlet valves
- ✓ For loose drive assembly or pump head screws
- ✓ Pressure switch operation/adjustment

### WILL NOT PRIME: (No discharge/motor runs)

- ✓ Strainer for debris
- ✓ Inlet/Outlet tube severely restricted (kinked)
- ✓ Inlet /Outlet valves for debris or swelling

### LEAKS FROM PUMP HEAD OR SWITCH:

- ✓ For loose screws at switch or pump head
- ✓ Switch diaphragm ruptured or pinched
- ✓ For punctured diaphragm if fluid is present at bottom drain holes

- Do not operate pump in an explosive environment. Arcing from the motor brushes, switch, or excessive heat from an improperly cycled motor may cause an explosion.
- Do not pump gasoline or other flammable liquids.
- Do not assume fluid compatibility. If the fluid is improperly matched to the pumps' elastomers, a leak may occur.
- "Intermittent Duty: is defined as: operated and/or frequently started within a period of time that would cause the motor to reach its maximum thermal limits. Once the maximum is obtain, the motor must be allowed to return to ambient temperature before resuming operation.

## SHURflo LOW VOLUME (SLV) INDUSTRIAL SERIES PUMPS

### SPECIFICATIONS:

MODEL NUMBER: SLV10 SERIES

PUMP DESIGN: Positive Displacement Pump

MOTOR: Permanent Magnet, 11-262-00

VOLTAGE: 12VDC

PRESSURE SWITCH: Factory set @ 40 PSI

Shut-off, Turn on 25± 5PSI

LIQUID TEMPERATURE: 110 Degrees Max

Fahrenheit (43 Degrees Centigrade)

PRIME: Self Priming Up to 2.5 Ft. Vertical

PORTS: 3/8" Barb

### MATERIAL OF CONSTRUCTION:

MOTOR HOUSING - Nylon

PLASTIC- Polypropylene

VALVES- Viton

DIAPHRAGM- Santoprene

FASTENERS- Zinc Plated/Stainless Steel

NET WEIGHT: 1.27 lbs

DUTY CYCLE: Intermittent

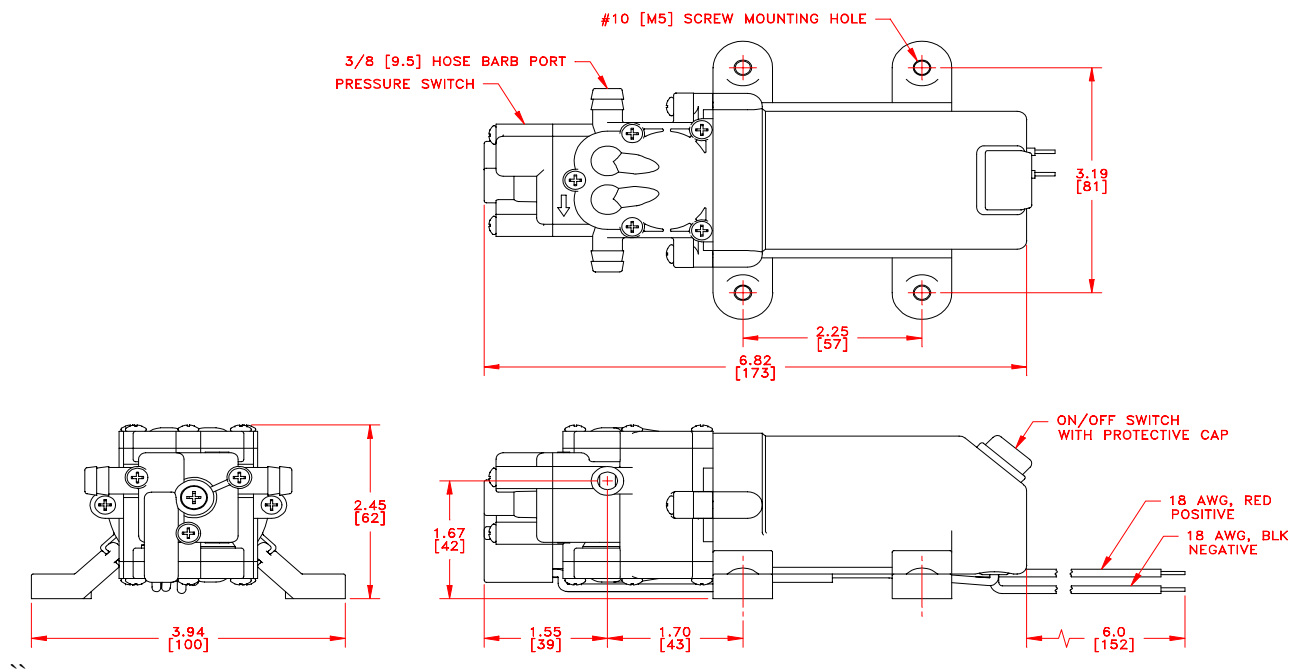
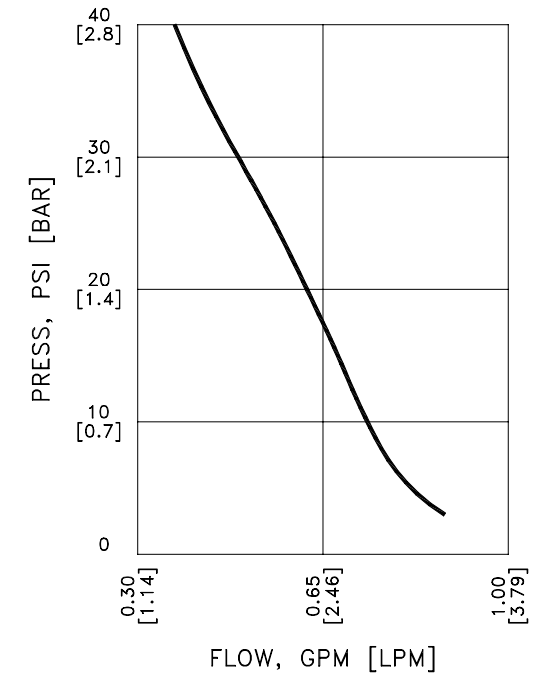

## **RETURN POLICY**

All Industrial pumps/products **must** be flushed of **any** chemical (ref. OSHA Section 1910.1200 (d)(e)(f)(g)(h)) and hazardous chemicals **must** be labeled/tagged before being \*shipped to SHURflo for service or warranty consideration. SHURflo reserves the right to request a Material Safety Data Sheet from the returnee for any pump/product it deems necessary. SHURflo reserves the right to "disposition as scrap" pumps/products returned which contain unknown fluids. SHURflo reserves the right to charge the returnee for any and all costs incurred for chemical testing, and proper disposal of components containing unknown fluids. SHURflo request this in order to protect the environment and personnel from the hazards of handling unknown fluids.

## **LIMITED WARRANTY PROCEDURE**

SHURflo warrants Shurflo Low Volume (SLV) series pumps to be free from material and workmanship defects (under normal use and service) for a period of one (1) year from the date of manufacture. Alternatively, (1) one year use with proof of purchase, not to exceed (2) two years in any event.

The limited warranty will not apply to pumps that were improperly installed, misapplied, or incompatible with fluids or components not manufactured by SHURflo. SHURflo will not warrant any pump, which is damaged or modified outside the SHURflo factory.

All Industrial pumps/products **must** be flush of **any** chemicals before \*shipping. SHURflo's written Return Policy governs all warranty considerations.

Returns are to be shipped postage prepaid to either service center; SHURflo Garden Grove, CA or Elkhart, IN. SHURflo shall not be liable for freight damage incurred during shipping. Package returns carefully.

Upon receiving a pump, it will be tested per SHURflo's test criteria. SHURflo's obligation under this warranty policy is limited to the repair or replacement of the unit. Pumps found not defective (under the terms of this limited warranty) are subject to charges to be paid by the returnee for the testing and packaging of "tested good" units.

No credit or labor allowances will be given to the returnee for pumps returned as defective. Warranty replacements will be shipped on a freight allowed basis. SHURflo reserves the right to choose the method of transportation.

This limited warranty is in lieu of all other warranties, expressed or implied, and no other person is authorized to give any other warranty or assume obligation or liability on SHURflo's behalf. SHURflo shall not be liable for any labor, damage or other expense, nor shall SHURflo be liable for any indirect, incidental or consequential damages of any kind incurred by the reason of the use or sale of any defective product or part. This limited warranty covers pumps distributed within the United States of America. Other world market areas should consult with the distributor for any deviation from this document.

\* Carriers, including U.S.P.S., airlines, UPS, ground freight, etc.; require specific identification of any hazardous materials being shipped. Check with your shipping company for specific instructions. Failure to do so may result in substantial penalties.



*SHURflo reserves the right to update specifications, prices, or make substitutions.*

**SHURflo ★**  
12650 Westminster Ave.  
Santa Ana, CA 92706-2100  
(800) 854-3218 (714) 554-7709  
FAX (714) 554-4721  
**Shipping/UPS:** 12650 Westminster Ave.  
Garden Grove, CA 92843

**SHURflo East**  
52748 Park Six Court  
Elkhart, IN 46514-5427  
(800) 762-8094  
(219) 262-0478  
FAX (219) 264-2169  
© 1998 Printed in USA

**SHURflo Ltd.**  
Unit 5 Sterling Park  
Gatwick Road, Crawley  
West Sussex, RH10 2QT  
United Kingdom  
+44 1293 424000  
FAX +44 1293 421880